

Required Tools

1/2" Wrench



Power Tool with  
Phillips head



## GENERAL HARDWARE/ACCESSORIES

PART#	DESCRIPTION	1 BAR	2 BAR	3 BAR	4 BAR	ITEMS (NOT DRAWN TO SCALE)
B016	5/16" X 1 1/4" CARRIAGE BOLT	4	8	12	16	
B018	5/16" X 1 3/4" CARRIAGE BOLT	1	2	4	5	
B201	1/2" PHILLIP TAP SCREWS`	4	8	12	16	
W008	5/16" X 3/4" WASHER	4	8	12	16	
N005	5/16" NYLON NUTS	4	8	12	16	
N016	PLASTIC KNOB	0	2	4	5	
A02	LADDER GUIDE	0	1	2	2	
A06	LADDER STOPPER	0	1	2	3	
A69	EZ VELCRO STRAP	0	1	2	3	
A88	PLASTIC BAR GUARD	1	2	3	4	
H11/H12	DRIP RAIL CLAMP 2" X 8"	2	4	6	8	
	UPRIGHT MOUNTING BASE (REFER TO CHART BELOW)	2	4	6	8	
	CROSS BAR (REFER TO CHART BELOW)	1	2	3	4	
	RUBBER SEAT	2	4	6	8	

MAKE	CHEVY VAN	CHEVY EXPRESS	DODGE	FORD ECONOLINE	FORD ECONOLINE	GMC VAN	GMC SAVANA
YEAR	UP TILL 1996	1996 AND ON	ALL	UP TIL 1991	1992 AND ON	88-96	1996 AND ON
FRONT BAR	9", 63"	9", 57"	9", 63"	9", 63"	9", 63"	9", 63"	9", 57"
MIDDLE BAR 1	9", 63"	8 3/8", 57"	9", 63"	9", 63"	8 3/8", 63"	9", 63"	8 3/8", 57"
MIDDLE BAR 2	9", 63"	8 3/8", 57"	9", 63"	9", 63"	8 3/8", 63"	9", 63"	8 3/8", 57"
REAR BAR	9", 63"	9", 56"	9", 62"	9", 63"	9", 62"	9", 63"	9", 56"

Sprinter 02-06 receive all high mounts with 65" Bars.

Packaged by \_\_\_\_\_

Date \_\_\_\_\_

[ ] **FORD ECONOLINE 1992 & ON**

Upright Mounting Base Heights

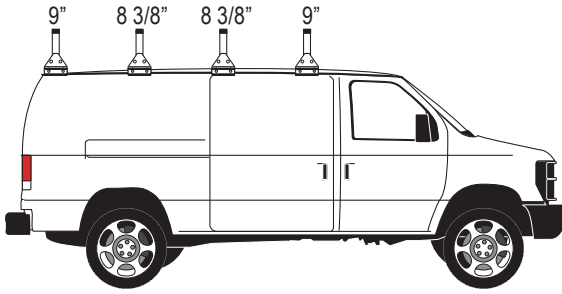

Crossbar Lengths

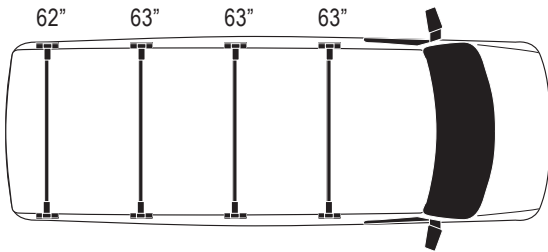

[ ] **DODGE RAM VAN (ALL YEARS)**

Upright Mounting Base Heights

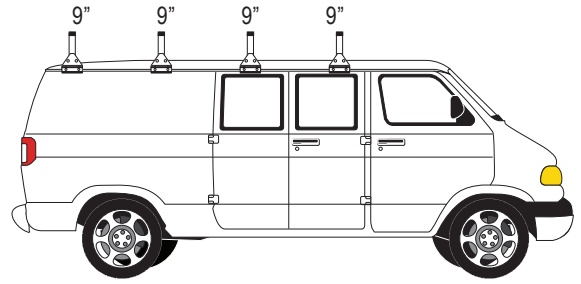

Crossbar Lengths

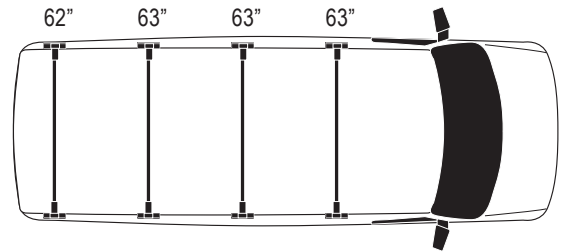

[ ] **CHEVY VAN (TILL 96)**

[ ] **GMC VAN (TILL 96)**

[ ] **FORD ECONOLINE (TILL 1991)**

Upright Mounting Base Heights

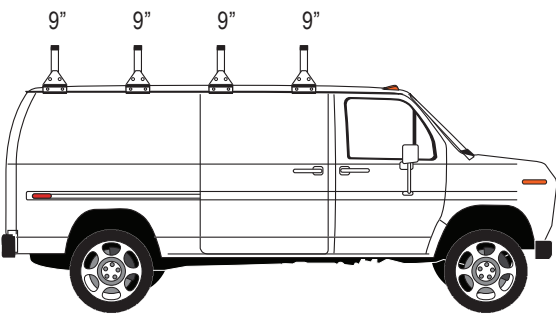

Crossbar Lengths

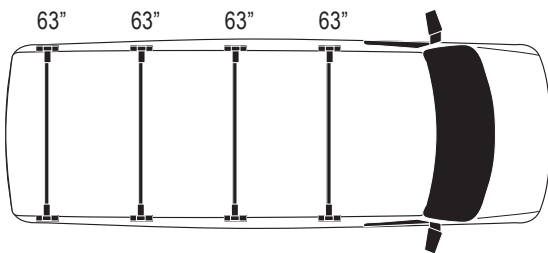

[ ] **GMC SAVANA 1996 & ON**

[ ] **GMC EXPRESS 1996 & ON**

Upright Mounting Base Heights

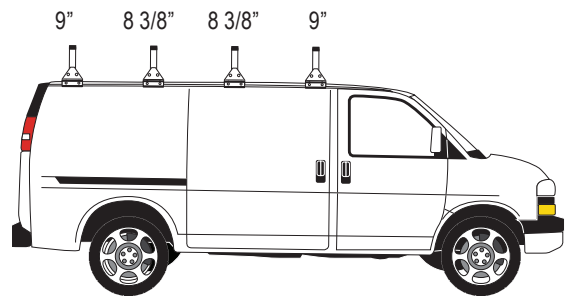

Crossbar Lengths

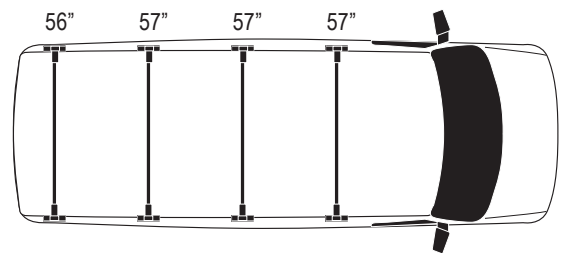

## PLASTIC BAR GUARDS FOR STEEL CROSS BARS

- Remove wax paper from Plastic Bar Guard and adhere it to the top of the Cross Bar.

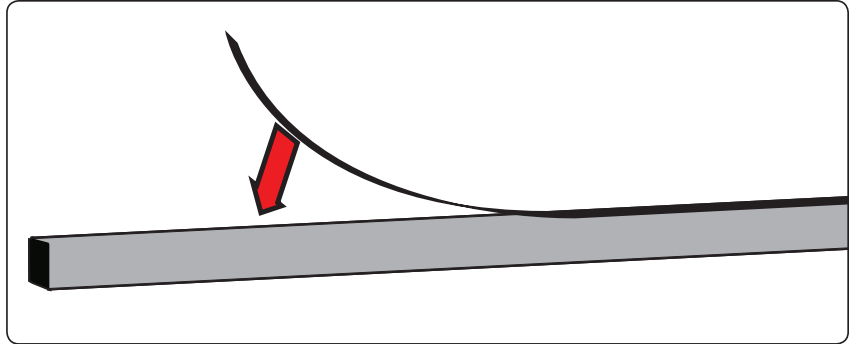
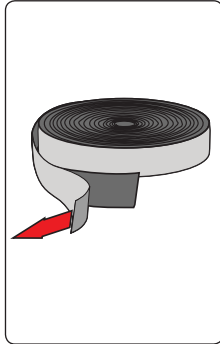

## RUBBER SEATS FOR UPRIGHT MOUNTS

- Slide the Rubber Seats onto the bottom of the Upright Mounts.

- These prevent metal on metal contact for vehicles without a protective layer on their drip rail.

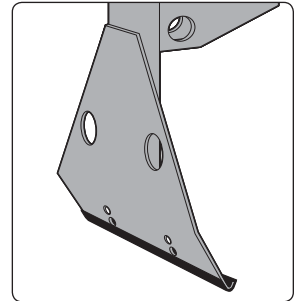
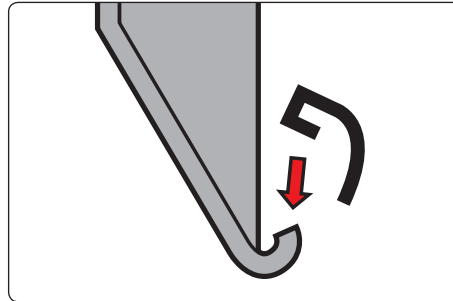

## EZ VELCRO STRAP

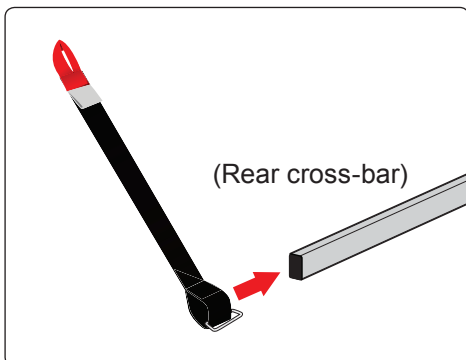

Insert rear cross-bar into opening of EZ-velcro straps.

### How it works

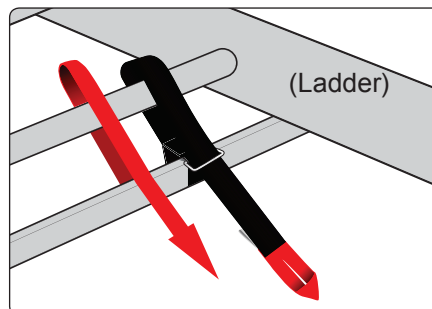

Slide strap around equipment the through steel ring.

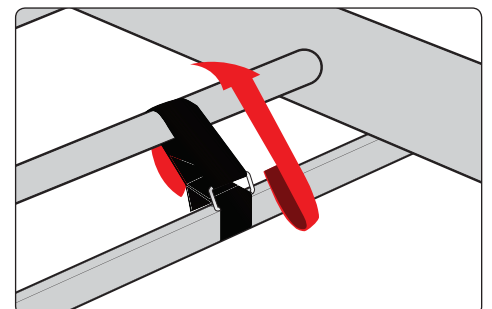

Pull EZ-velcro to secure via velcro.

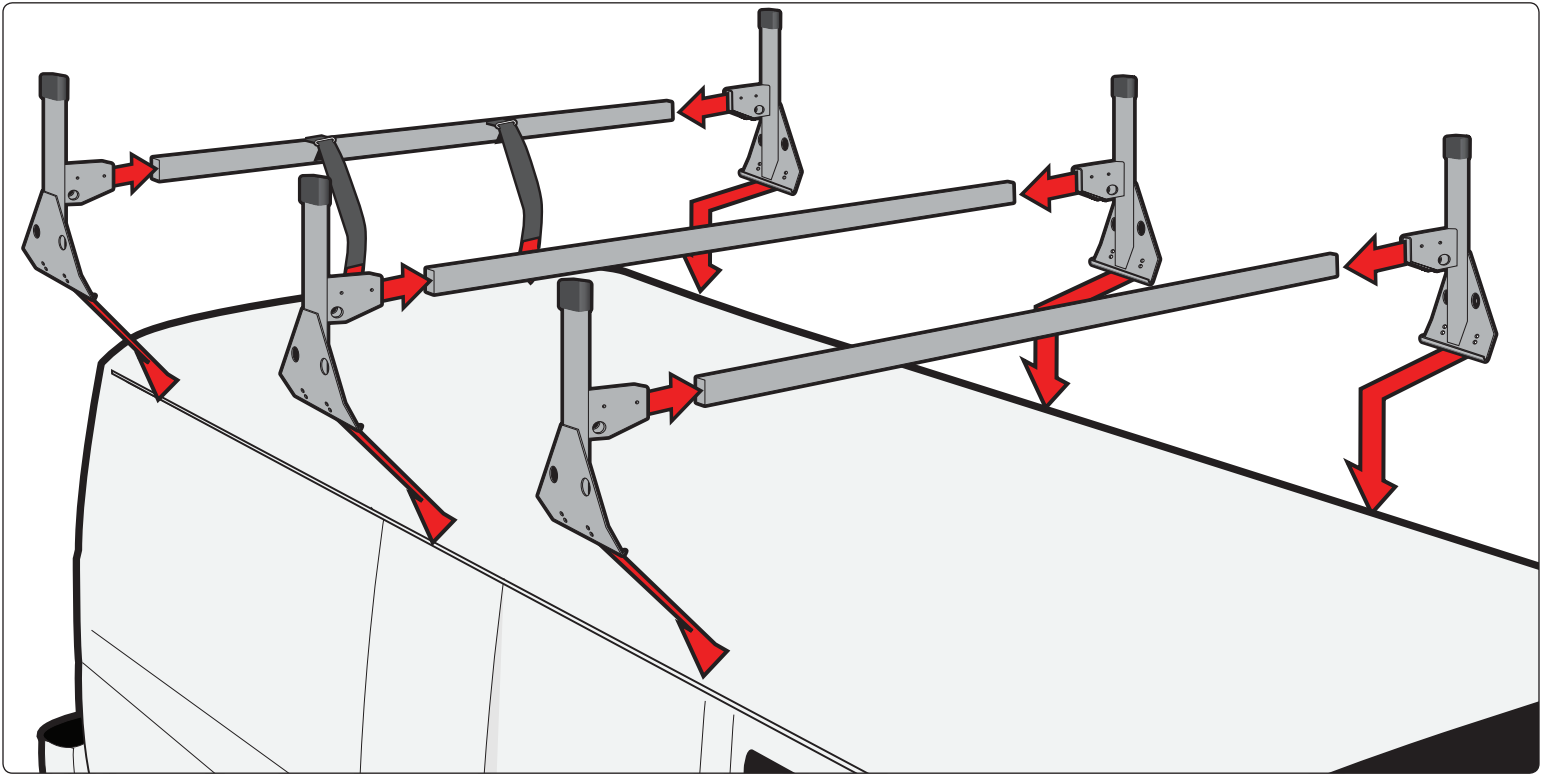

- Height of upright and length of crossbars are vehicle specific. Please refer to page 3 for correct measurements.
- Front bar should be positioned 6" behind front doors to prevent wind noise/rattle.
- Refer to chart on page 3 for correct upright and bar positioning.

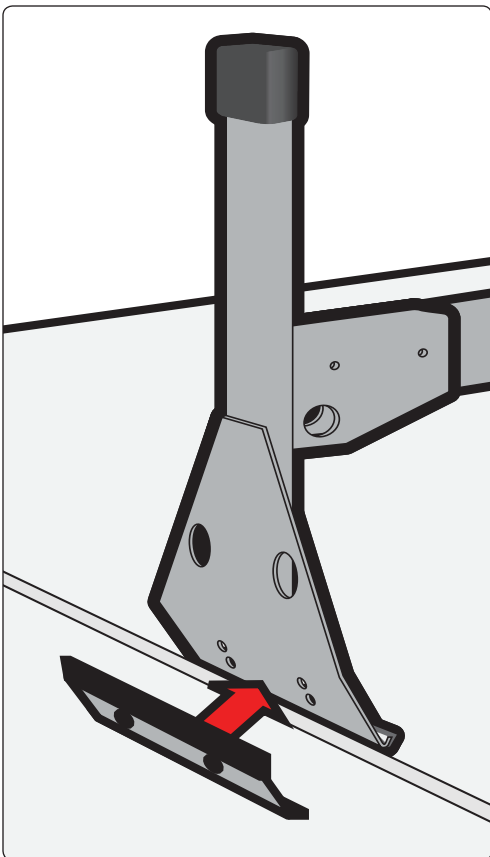

**Chevy Express 96-Present**  
**GMC Savana 96-Present**

Secure the mounting plate to the "bottom" holes of the upright mounts.

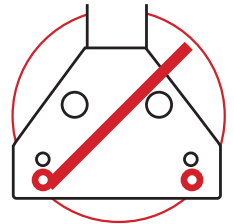
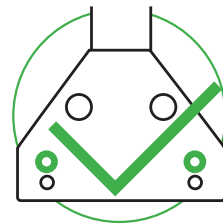

**Chevy Van GMC Up & Till 96**  
**Dodge All Years**  
**Dodge Sprinter 2002-2006**  
**Ford All Years**

Secure the mounting plate to the "top" holes of the upright mounts.

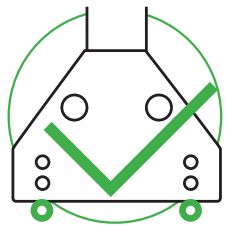
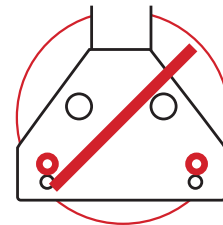

- For Ford Econoline 92-present turn the mounting plate so the hole are slightly higher.
- Except for the Passenger side barn door. Flip the mounting plate 180° so doors can open freely.



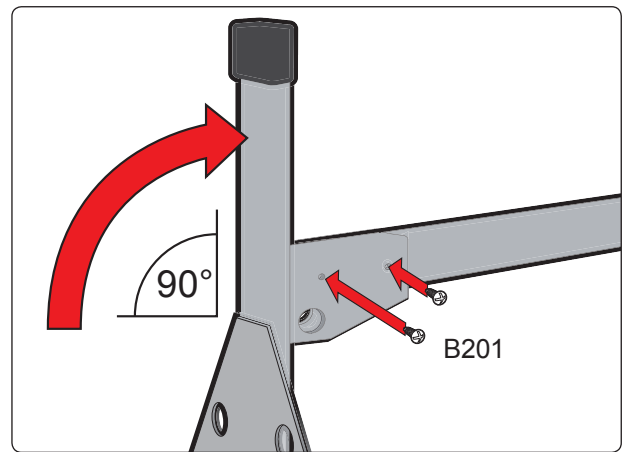
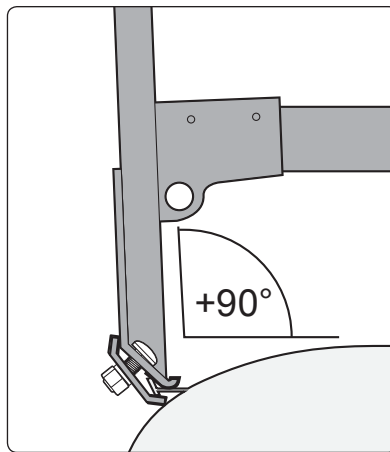
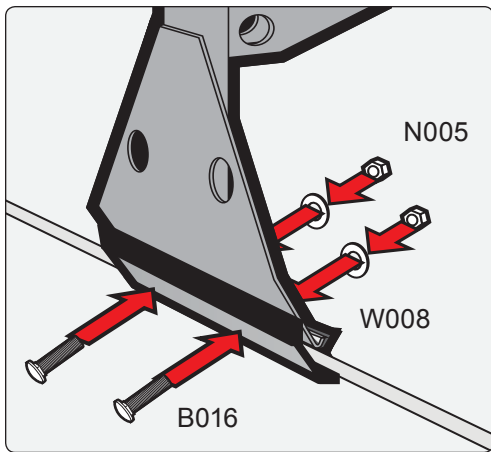

-Tightly secure hardware.  
 -Upright mounting base will crimp the drip rail and angle outwards as hardware is tightened.

Push the upright so it's 90 degrees then secure with tap screws.

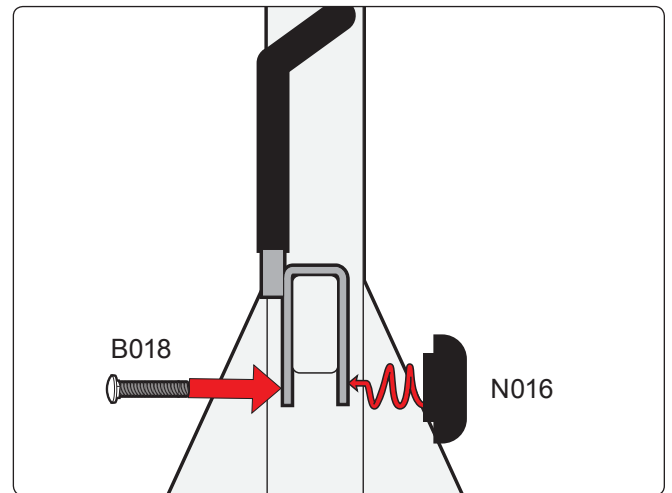
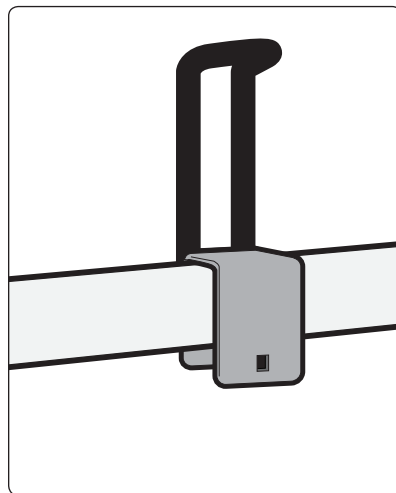
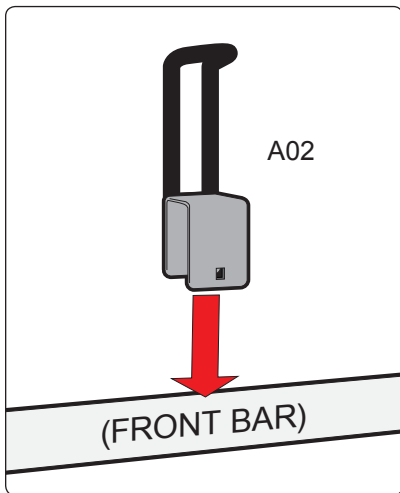

- Ladder Stopper can be installed in the front bar with tip facing the rear, allowing the ladder steps to fit in between. The bend of the Ladder Stopper prevent the ladder from rattling.

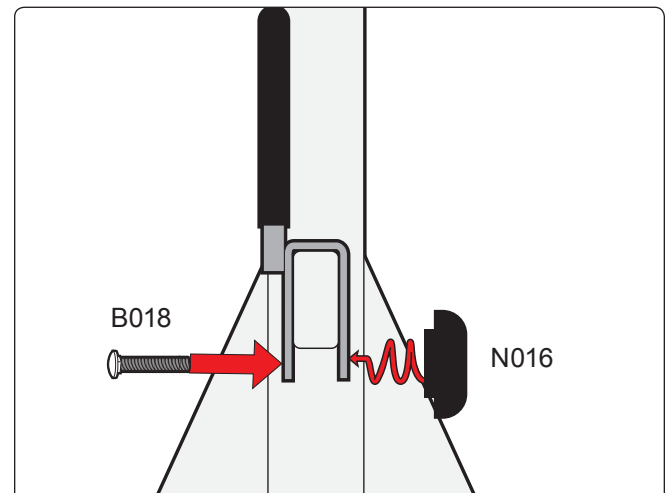
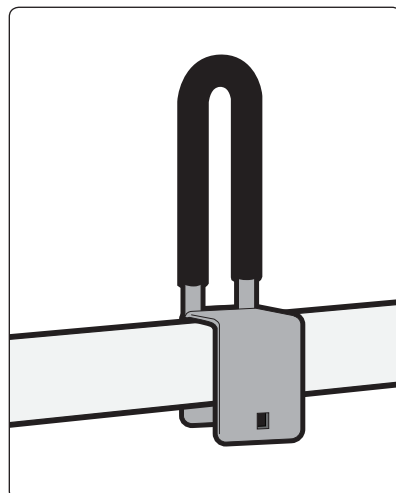
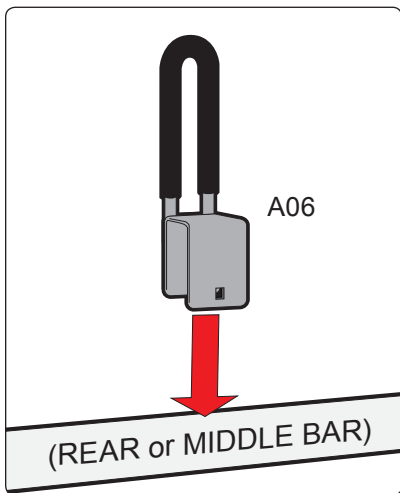

- Ladder Guide can be installed in the rear bar or middle bar to guide ladders down the system.